

Material:				Volume:	
Date	Drawn by	Mechanics VARIMAT V2		Sheet	1
20.03.2009	bdu			of	1
Date	Checked by			Revision	1
18.11.2009	gdm	Format	Scale	Drawing number	020.294
LEISTER Process Technologies CH-6060 Sarnen		A2	%	A	

This document and the information in it contained are property of LEISTER and as such, they are to be considered reserved.
 Therefore, any reproduction in any form or by any means, without prior written permission of LEISTER is forbidden.

A

B

C

D

E

F

1

2

3

4

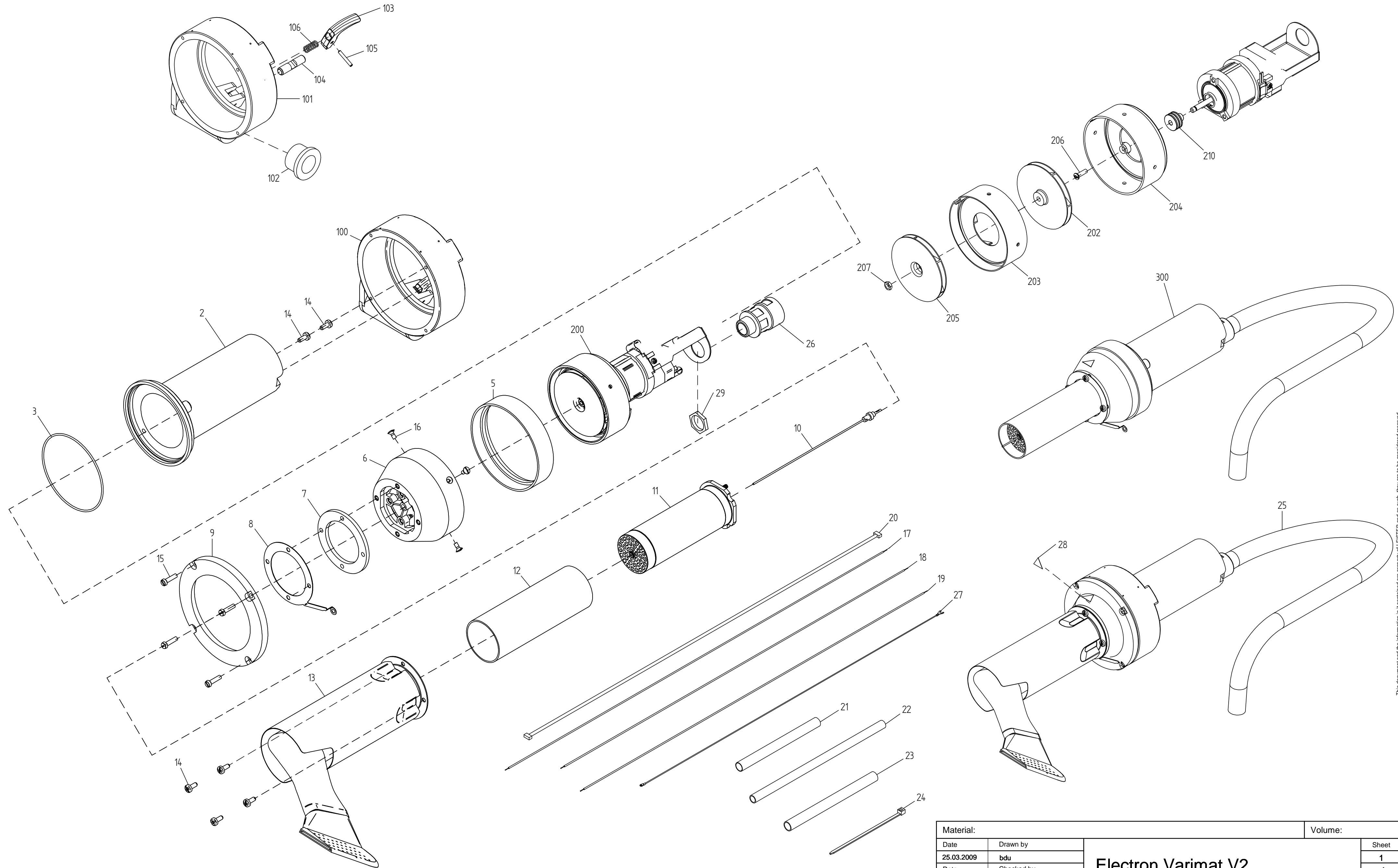

Material:		Volume:	
Date	Drawn by	Sheet	
25.03.2009	bdu	1	
Date	Checked by	of	
18.11.2009	gdm	1	
LEISTER Process Technologies CH-6060 Samen		Format	Scale
		A2	%
		Drawing number	
		020.362	
		Revision	
		A	

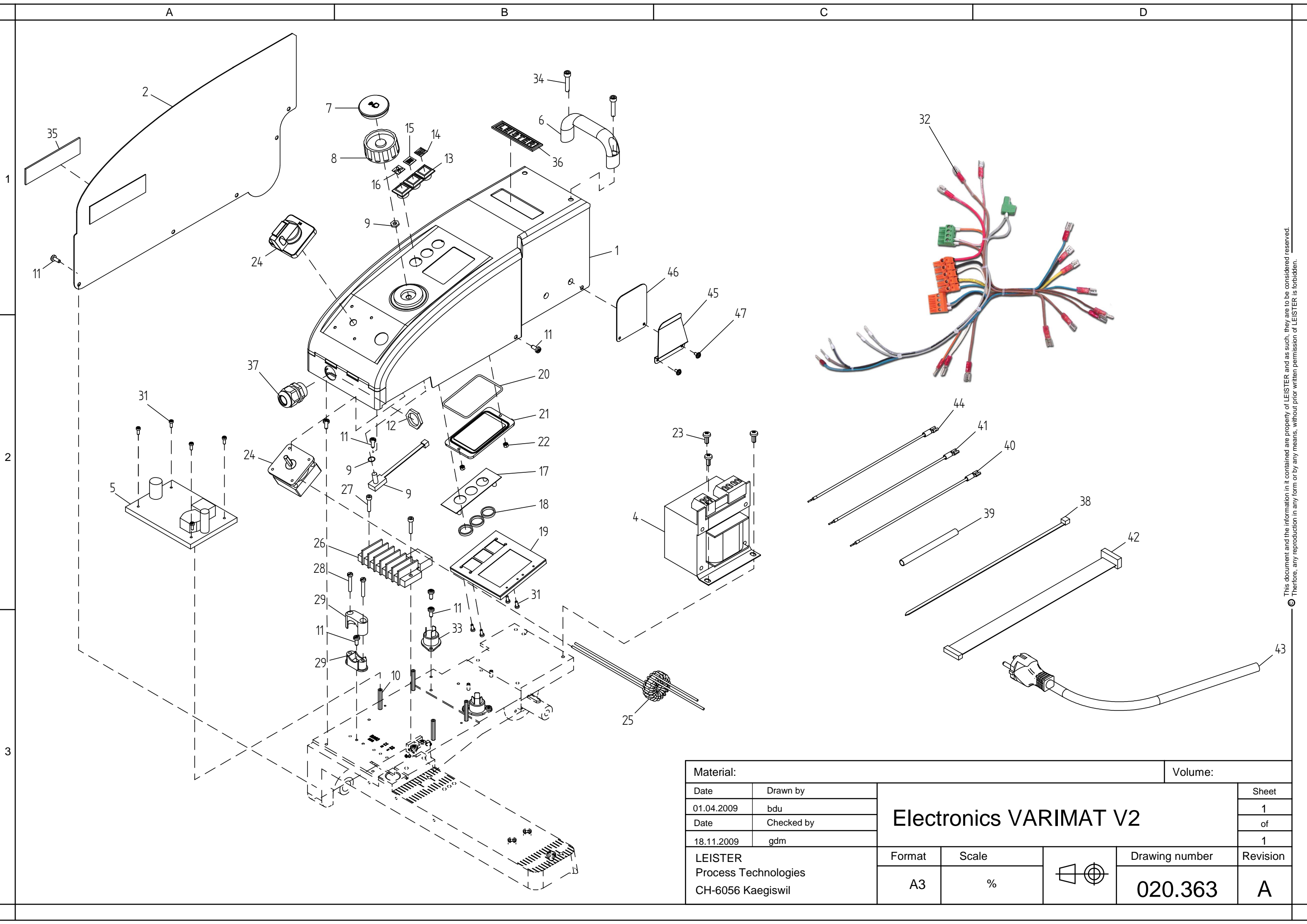

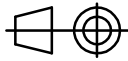
Material:				Volume:		
Date	Drawn by	Electronics VARIMAT V2			Sheet	
01.04.2009	bdu				1	
Date	Checked by				of	
18.11.2009	gdm				1	
LEISTER Process Technologies CH-6056 Kaegiswil		Format	Scale		Drawing number	Revision
		A3	%		020.363	A

Spare Parts List: VARIMAT V2 dc0947				List Price \$
Drawing-No 020.294A, 020.362B, 020.363A				
Pos	Order No	Qty	Article	
Drawing-No 020.294A (Mechanics VARIMAT V2)				
1	107.073	1	Undercarriage complete	1,490.00
2	107.066	1	Basic weight complete	232.00
3	107.067	1	Additional weight complete	178.00
4	107.065	1	Terminal weight complete	178.00
7	104.266	1	Rollpin spring ø 4 x 20	4.00
8	137.696	1	Guiding bar bottom	220.00
10	113.355	1	Pinch roll complete, with bearing bush and rocker	544.00
11	107.068	1	Roller complete	426.00
12	107.081	1	Swivel-joint roller	452.00
14	108.115	1	Driving axle	152.00
15	107.074	1	Rocker complete	172.00
16	107.699	1	Rocker complete	178.00
17	115.989	1	Guide shaft complete	64.00
18	107.092	1	Axle suspension	202.00
19	107.072	1	Roller holder complete	28.00
20	107.051	1	Axle	216.00
21	107.069	1	Deflection roller complete	190.00
22	107.084	1	Carrier bush	202.00
23	100.985	2	Silicon rubber ring ø 62/82 x 51mm	90.00
26	114.500	1	Pillow block	82.00
27	107.703	1	Guide roller complete	72.00
28	107.079	1	Axle	58.00
29	107.732	1	Knob M6	54.00
30	107.731	1	Spring	22.00
31	135.192	1	Crank 40	17.00
32	107.053	1	Retaining disk	64.00
33	107.085	1	Chain adjuster	82.00
34	107.047	1	Adjusting pendulum	40.00
35	107.044	1	Collar screw	102.00
36	107.045	2	Set collar	68.00
37	107.729	2	Rubber buffer	56.00
38	107.046	1	Spring washer	56.00
39	107.042	1	Collar screw	102.00
40	115.988	1	Cover sheet	17.00
41	137.706	1	Clamping lever M6 x 20	17.00
42	138.817	1	hand brush, stainless	14.00
43	104.255	1	Cable fixation clip ø 11	16.00
44	110.553	1	Chain joint 8 x 3mm	10.00
44	114.113	1	Roller chain 8 x 1/8" x 408mm (12m/min)	76.00
45	100.326	1	Clamp disk	30.00
46	107.052	1	Bearing bush	92.00
47	137.953	1	Sensor complete with plug	242.00
48	108.210	1	Clamping sleeve	11.00
49	104.268	1	Internal retaining ring ø 52	36.00
50	104.270	1	External retaining ring ø 30	18.00
51	100.341	1	External retaining ring ø 15	3.00
52	100.356	1	External retaining ring ø 14	4.00
53	106.811	1	Parallel key 6 x 6 x 22	4.00
55	100.563	3	Deep groove ball bearing ø 6/19 x 6	26.00
56	102.241	1	Washer M4 4.3/12/1	3.00

Spare Parts List: VARIMAT V2 dc0947				List Price \$
Drawing-No 020.294A, 020.362B, 020.363A				
Pos	Order No	Qty	Article	
57	107.733	1	Spring washer M4 4.3/8/0.5	3.00
58	102.916	3	Shim ring 6/12/0.5	3.00
59	107.953	1	Spiral pin ø 5 x 30	2.00
60	101.095	1	Rollpin spring ø 5 x 22	4.00
61	104.224	1	Round belt	46.00
62	104.262	2	Circlip for shaft ø 8	3.00
63	107.730	1	Hexagon nut M10/0.8d	5.00
65	104.259	1	Cheese head screw M10 x 20	5.00
66	101.077	1	Cheese head screw M8 x 25	7.00
67	104.260	1	Cheese head screw M6 x 35	3.00
68	102.408	1	Countersunk screw M6 x 20	3.00
69	100.945	2	Slotted pan head screw M6 x 16	3.00
70	100.299	3	Fillister head screw M4 x 10	3.00
71	101.113	2	Cheese head screw M6 x 20	3.00
72	100.979	3	Hexalobular socket pan head screw M6 x 12	5.00
74	100.424	2	Cheese head screw M5 x 16	4.00
75	104.261	2	Fitted shoulder screw M6 x 12, with socket head	10.00
77	104.263	1	Springy thrust piece M8 x 16	3.00
78	104.258	1	Set screw M8 x 14	4.00
79	100.398	3	Set screw M4 x 8t	3.00
80	101.113	2	Cheese head screw M6 x 20	3.00
81	106.732	2	Cheese head screw M4 x 20	3.00
82	100.976	1	Hexalobular socket pan head screw M5 x 12	5.00
83	119.503	1	Washer M8	28.00
85	104.225	2	Pressure spring ø 0.9 x ø 13.5 x 37.5	7.00
89	100.970	1	Countersunk screw M4 x 12	3.00
90	101.008	1	Spring ring M4 4.25/7.6/0.9	2.00
91	100.142	1	Thread forming fillister head screw M5 x 12	3.00
92	100.124	2	Spring ring M5 5.35/9.2/1.2	2.00
93	100.173	2	Torsional protection disk	3.00
94	132.429	2	Solder plate 200x100x0.5mm	14.00
95	130.275	1	Snap hook	11.00
200	108.125	2	Holding-down roller	50.00
201	107.055	2	Guide pillar	56.00
202	107.056	2	U-profile	72.00
203	107.077	2	Holding-down roller	68.00
204	104.267	2	Rollpin spring ø 8 x 20	5.00
205	100.299	2	Fillister head screw M4 x 10	3.00
300	138.074	1	Drive unit 12m/min.	1,616.00
301	107.061	1	Gear support	190.00
302	114.116	1	Motor DCS 52/33, 230V, 12m/min	1,148.00
303	115.941	1	Electronic circuit board ZPM 06 complete, 230V	334.00
304	114.109	1	Motor support 12m/min	76.00
305	114.112	1	Toothed belt 5/16", 12m/min	28.00
306	127.414	1	Planetary gear 195:1	574.00
307	127.419	1	Chain wheel 12m/min 11mm wide	70.00
308	114.088	1	Fan complete, 12V	118.00
309	100.429	2	Carbon brush 5 x 6 x 14 with lead (230/200V)	6.00
310	115.070	1	Lock washer	22.00
311	103.782	2	Cheese head screw M4 x 60	2.00
312	112.503	1	Cheese head screw M4 x 40	3.00

Spare Parts List: VARIMAT V2 dc0947				List Price \$
Drawing-No 020.294A, 020.362B, 020.363A				
Pos	Order No	Qty	Article	
313	100.142	4	Thread forming fillister head screw M5 x 12	3.00
314	106.481	2	Distance bolt M4, hexagon, with threaded stud	4.00
315	106.732	4	Cheese head screw M4 x 20	3.00
316	103.361	1	External retaining ring ø 8	2.00
317	101.060	1	External retaining ring ø 12	2.00
318	101.598	2	Distance bush M3 3.1/6/5	2.00
319	100.270	1	Thread forming fillister head screw M3 x 6	3.00
320	100.208	2	Cheese head screw M3 x 12	3.00
400	137.843	1	Guiding bar upper part complete	419.00
401	137.692	1	Guiding bar pipe above	296.00
402	137.842	1	Guiding bar with handle	140.00
403	137.689	1	Pipe latch	15.00
404	137.709	1	Feather key 3x3x18	78.00
405	120.809	1	Cheese head Screw M 4 x 10	3.00
406	100.617	1	Hexagon nut M4/0.8d	2.00
500	108.120	1	Pinch roller	190.00
501	107.071	1	Pinch roll complete	190.00
502	107.093	1	Rubber ring ø 74/92 x 40	42.00
Drawing-No 020.362B (Electron VARIMAT V2)				
2	137.757	1	Electron housing	50.00
3	101.237	1	O-ring ø 75.92 x ø 1.78mm	3.00
5	101.252	1	Rubber ring without cams	12.00
6	126.708	1	Turbine housing upper part, with 3 plug sockets	94.00
7	101.270	1	Gasket 70 x 48 x 4mm	18.00
8	114.709	1	Earth/ground ring (unfold)	14.00
9	100.909	1	Retaining ring 120 x 8mm	34.00
10	112.693	1	Thermocouple	188.00
30	107.687	2	End sleeve, 0.5mm2, white	2.00
11	107.612	1	Heating element type 39A1, 230V/2200+2200W	390.00
12	101.274	1	Mica tube ø 47.6 x 134mm	60.00
13	138.460	1	Speed overlap welding nozzle 40mm	578.00
14	100.299	6	Fillister head screw M4 x 10	3.00
15	100.442	4	Cheese head screw M4 x 16	3.00
16	101.269	4	Fillister head countersunk screw M3.5 x 8	3.00
17	107.760	1	Temperature resistant wire 1.5mm2 x 1100mm, black	6.00
18	107.764	1	Temperature resistant wire 2.5mm2 x 1m, blue	6.00
19	107.759	1	Temperature resistant wire 1.5mm2 x 1m, yellow	6.00
31	106.196	3	Flat receptacle 6.3 x 0.8mm (2.5mm2), blue	2.00
20	137.934	1	Flex print MCU 03	64.00
21	107.765	1	Insulating tube ø 8 x 0.5 x 90mm, white	4.00
22	107.749	1	Silicon tube ø 8 x 0.5 x 150mm, white	6.00
23	112.155	1	Insulating tube ø 7 x 0.7 x 100mm, white	2.00
24	100.151	1	Cord fastener 85 x 22	2.00
25	137.752	1	Cable protection corrugated pipe NW17	17.00
26	112.305	1	Hose screw fitting PG 11, NW 17, straight, black	17.00
27	138.355	1	Flex wire 20AWG x 820, ye/gn	10.00
28	100.528	1	Warning label "Hot surface"	6.00
29	112.273	1	Counternut PG 11	2.00
100	115.427	1	Tool holder complete	222.00
101	115.425	1	Tool holder with flange sleeve	258.00

Spare Parts List: VARIMAT V2 dc0947				
Drawing-No 020.294A, 020.362B, 020.363A				
Pos	Order No	Qty	Article	List Price \$
102	115.426	2	Flange sleeve ø 20/28/35 x 20mm	42.00
103	100.359	1	Trigger	24.00
104	100.360	1	Lock pin	32.00
105	100.362	1	Rollpin spring ø 3 x 20	3.00
106	100.361	1	Pressure spring	3.00
200	137.736	1	BL Motor V2 45/25 S complete, 230V	538.00
202	107.591	1	Turbine	21.00
203	107.762	1	Distributor complete	30.00
204	104.064	1	Turbine housing lower part complete	32.00
205	107.592	1	Turbine	21.00
206	100.284	3	Thread forming fillister head countersunk screw M4 x 14	3.00
207	100.287	1	Hexagon nut M5/0.5d	2.00
210	117.293	1	Distance disc	10.00
300	140.138	1	ELECTRON VARIMAT V2, 230V complete with out nozzle	1,308.00
Drawing-No 020.363A (Elektronics VARIMAT V2)				
1	136.074	1	Housing cap	426.00
2	135.646	1	Housing cap side	105.00
4	137.944	1	Auto transformer	298.00
5	137.995	1	Electronic circuit board TRN 06, 200/230V	525.00
6	135.153	1	Carrying handle	52.00
7	138.017	1	Cover for e-Drive	2.00
8	134.949	1	e-Drive	13.00
9	138.045	1	Electronic circuit board encoder ECI 01D, 5V	86.00
10	114.739	4	Distance bolt M3, hexagon, with inside thread	4.00
11	100.299	14	Fillister head screw M4 x 10	3.00
12	113.567	1	Hexagon counternut M20 x 1.5	2.00
13	116.531	3	Luminous push button socle	7.00
14	135.167	1	Pressure button drive	10.00
15	135.166	1	Pressure button temperature	10.00
16	135.165	1	Pressure button air	10.00
17	135.939	1	Retaining cover	24.00
18	116.532	3	Mounting nut	5.00
19	138.046	1	Electronic circuit CSE 07B	767.00
20	137.798	1	Display seal	8.00
21	134.950	1	Display window	6.00
22	101.180	2	Locking nut M3, hexagon	2.00
23	100.142	3	Thread forming fillister head screw M5 x 12	3.00
24	101.557	1	On-Off-switch	76.00
25	101.198	1	Toroidal core complete	58.00
26	107.694	1	Snap-on connector board with capacitor	104.00
27	106.732	2	Cheese head screw M4 x 20	3.00
28	101.116	2	Cheese head screw M4 x 25	3.00
29	111.718	1	Cord clip ø 9 - 19mm, enlarged	7.00
31	100.816	8	Cheese head screw M3 x 8	3.00
32	127.095	1	Cable loom V2, 230V	212.00
33	101.187	2	Triac 25A/800V	96.00
34	100.872	2	Cheese head screw M5 x 25	3.00
35	137.862	1	Company label LEISTER (3D)	17.00

Spare Parts List: VARIMAT V2 dc0947				List Price \$
Drawing-No 020.294A, 020.362B, 020.363A				
Pos	Order No	Qty	Article	
36	137.090	1	Company label LEISTER (3D)	11.00
37	113.582	1	Cable screw fitting M20 x 1.5, black	10.00
38	108.209	1	Cord fastener 4.8 x 300	2.00
39	112.155	2	Insulating tube ø 7 x 0.7 x 100mm, white	2.00
40	107.723	1	Temperature resistant wire 2.5mm ² x 225 complete, brown, with flat receptacles and end sleeve	10.00
41	107.721	1	Temperature resistant wire 2.5mm ² x 225 complete, blue, with flat receptacle and end sleeve	10.00
42	138.061	1	Ribbon cable	40.00
43	138.514	1	Power supply cord 3 x 2.5mm, 1.2m, with out plug	32.00
44	107.725	1	Temperature resistant wire 2.5mm ² x 215 complete, yellow-green, with flat receptacles and end sleeve	10.00
45	129.148	1	Metal holder	26.00
46	138.542	1	Protection cover for welding plattes	14.00
47	130.322	2	Pan washer head screw, M3 x 6	2.00