

# **SECTION SEVEN WARNING LABELS**

**TRUCK-MOUNTED CONVEYORS  
FBR-FIBERGLASS SERIES  
TURNTABLES- RTH 3000, RTH 4000,  
RTH 6000**



362 South Main, Clearfield, UT 84015  
801-773-1311 \* 800-453-2446 \*

Cleasby Conveyors (Rev. 04/28/00)

# SAFETY AND WARNING LABELS

## Labels Placed by Manufacturer

Cleasby Conveyors (CM) places a number of warning labels on the conveyor and turntable to warn of dangers and to remind operators of correct operating procedures.

---

### WARNING LABELS

The warning labels contain important warning information. Keep them visible and do not remove them.

---

Instruct operators to review the warning labels daily as they start to make their deliveries. This daily review of safety precautions will help your operators be more safety conscious, reducing hazards to themselves, and to others who may work near the conveyor.

Use care when cleaning to avoid damage to the warning labels by strong solvents or steam. Mask each label carefully before painting the unit. If the labels become damaged or unreadable, replace them promptly.

## Labels to be Placed by You or Your Installer

1.) Truck Cab Label. In addition to labels pre-installed on turntable and conveyor, Cleasby Conveyors provides two warning labels to attach to the dash of the truck (See #13 and #15). Mount these labels in clear view of the operator, and protect them from damage as described above.

2.) Truck Bed Label: Cleasby Conveyors also provides five (5) warning labels (see label #14 and #20) that must be placed at certain locations on the truck bed (See reference drawings for truck decal placement). These labels are 5 3/8 inches deep, so if the truck on which you are installing the conveyor is not thick enough to allow for good placement of these labels, mounting brackets for the labels are available from the manufacturer.

## Diagrams:

Following are various figures depicting the turntable and conveyor. Cleasby has pre-installed labels on the actual turntable and conveyors of which the figures are representative. Leader lines or arrows on the diagram designate each label's identification number and proper location on the equipment.

At the time of delivery to you (and periodically thereafter) look at the equipment with the manual in hand, checking each label in turn until you are satisfied that all labels are there, and that they are all positioned as specified in the manual.

---

## NOTE

Additional labels and truck bed mounting brackets are available free of charge. Call your local dealer, service center or distributor. If there is no dealer in your area, call Cleasby Conveyors (800) 453-2446.

---

CLEASBY CONVEYORS  
CONVEYOR DECAL  
PLACEMENT  
11-10-05

\* SEE NOTE \*

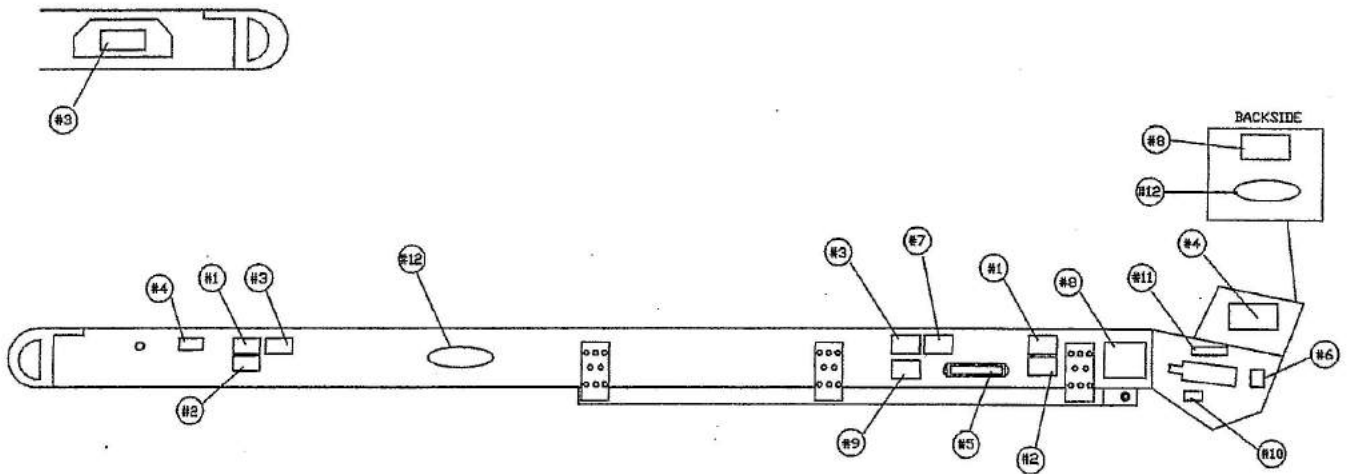

NOTE:  
ALL DECALS WITH THE EXCEPTION  
OF REAR OF LOADING GUARD AND  
# 5 ARE PLACED THE SAME WAY ON  
BOTH SIDES OF THE CONVEYOR

CLEASBY CONVEYORS  
362 S. MAIN, CLEARFIELD, UT 84015  
801-773-1311 \* 800-453-2446 \* FAX 801-773-8608

**CLEASBY CONVEYORS**  
**TURNTABLE DECAL PLACEMENTS**  
12-12-05

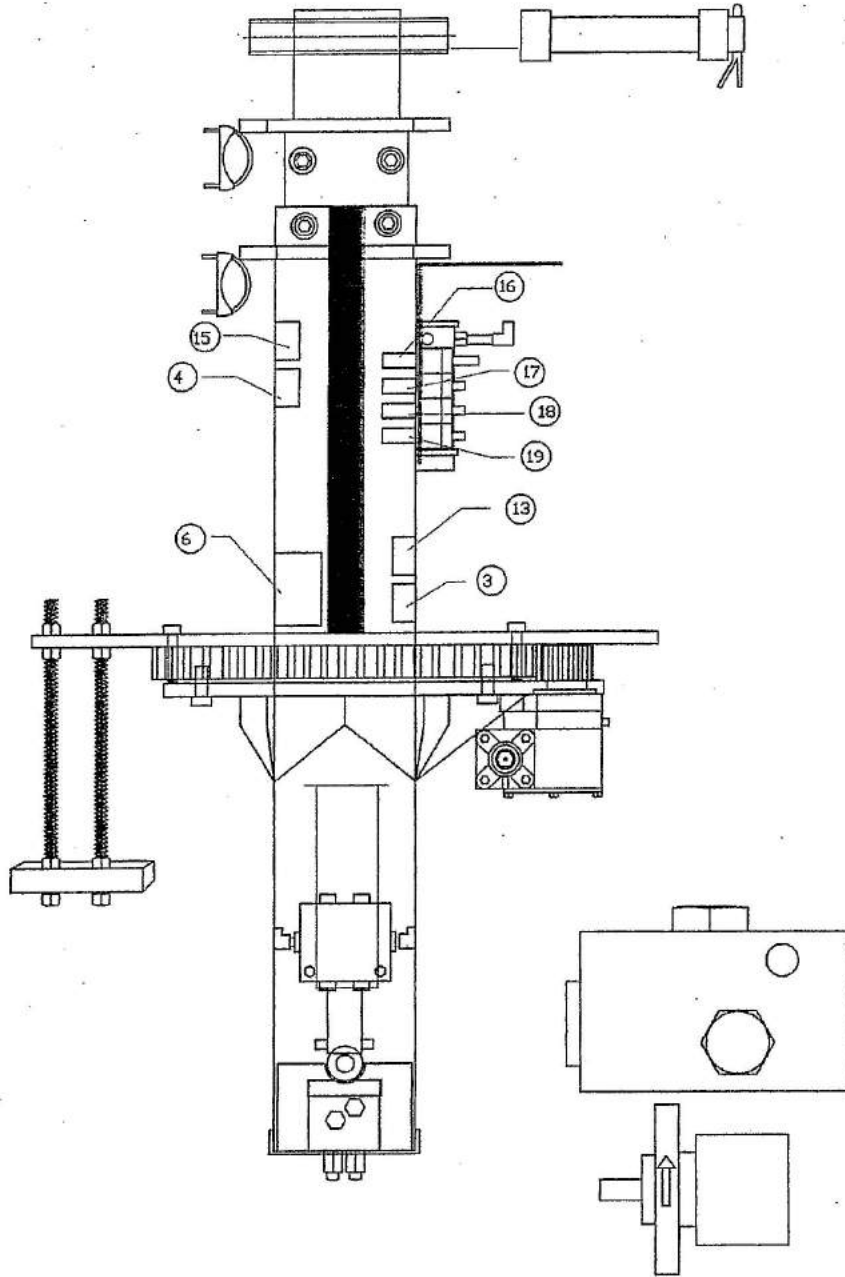

**CLEASBY CONVEYORS**  
**362 S. MAIN, CLEARFIELD, UT 84015**  
**801-773-1311 \* 800-453-2446 \* FAX 801-773-8608**

# TRUCK DECAL PLACEMENT

12-12-05

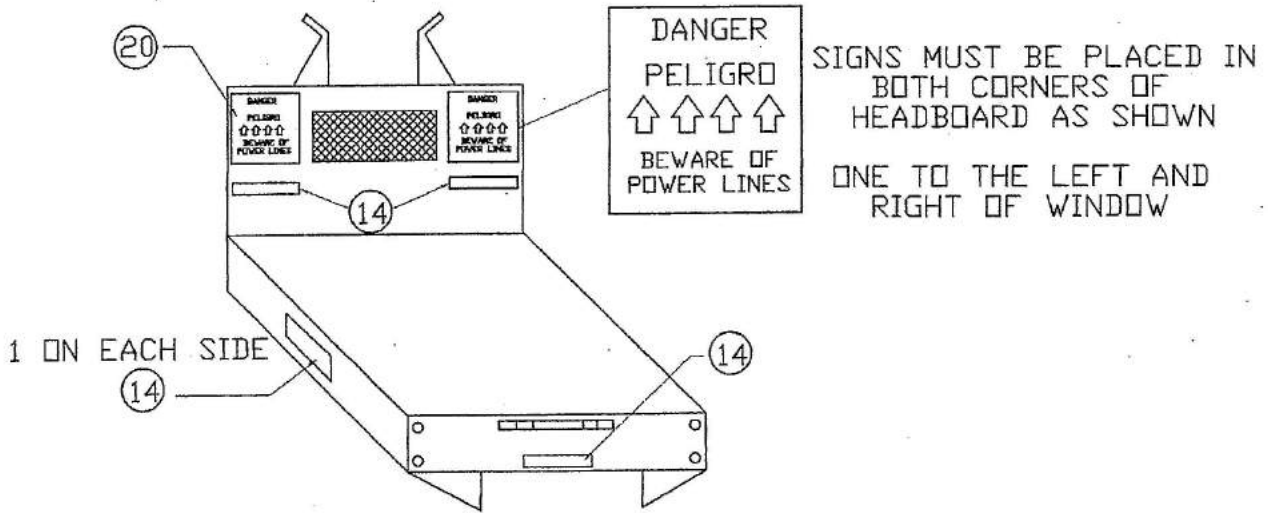
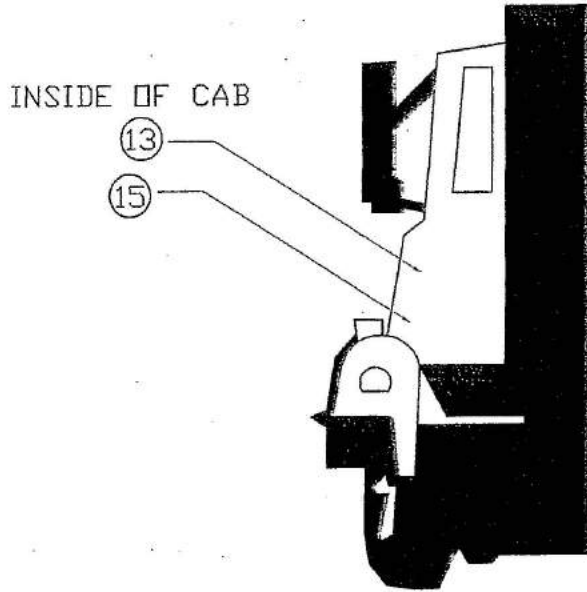

CLEASBY CONVEYORS

362 S. MAIN, CLEARFIELD, UT 84015

801-773-1311 \* 800-453-2446 \* FAX 801-773-8608

**CONVEYOR, TURNTABLE AND  
TRUCK DECALS  
12-20-05**

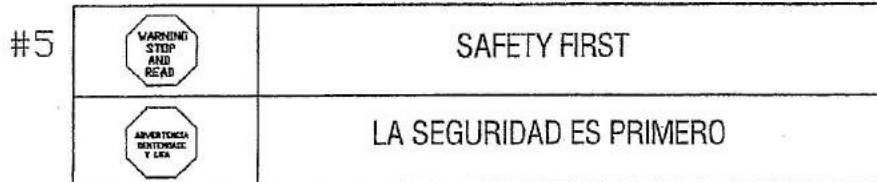
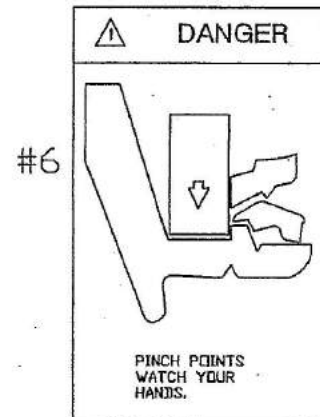
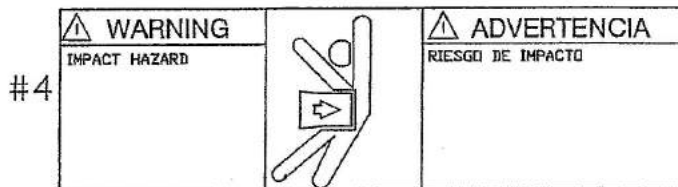
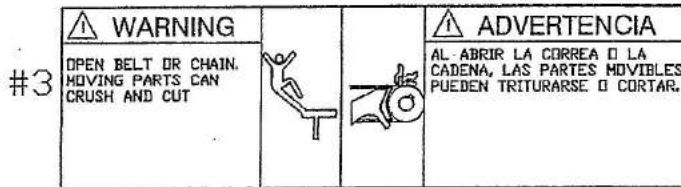
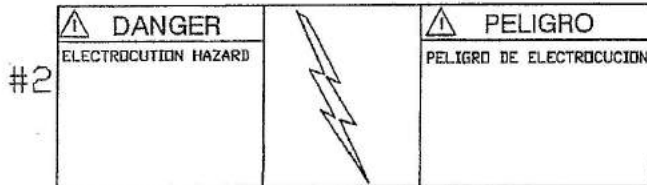
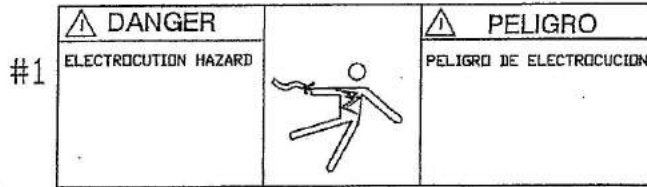



NOTE:  
NOT ALL WARNINGS ARE MENTIONED IN THESE  
DECALS. THEY HAVE BEEN SHORTNED TO FIT. DO  
NOT RELY ON WHAT THESE ILLUSTRATIONS SAY  
BUT WHAT THE ACTUAL DECALS INFORM.

**CLEASBY CONVEYORS**  
362 SOUTH MAIN, CLEARFIELD, UTAH 84015  
801 773-1311 \* 800 453-2446 \* FAX 801 773-8608

# CONVEYOR, TURNTABLE AND TRUCK DECALS

12-20-05

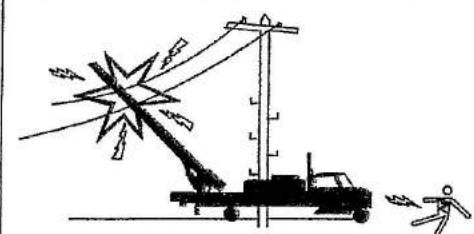

#7

|  |   |
|--|---|
|  <b>DANGER</b><br>RISK OF DEATH OR SERIOUS INJURY |  <b>PELIGRO</b><br>RIESGO DE MUERTE O LESION GRAVE |
|   |   |

#10

ADJUST  
 BELT TENSION AS  
 NEEDED.....HERE



#8

|   |  |
|---|--|
|  <b>WARNING</b><br>SAFETY INSTRUCTIONS |  <b>ADVERTENCIA</b><br>INSTRUCCIONES DE SEGURIDAD |
| IT IS UNLAWFUL TO OPERATE WITHOUT FOLLOWING THESE INSTRUCTIONS  | PROHIBIDO OPERAR SIN SEGUIR LAS SIGIENTES INSTRUCCIONES.   |

#11

1000 LB. CAPACITY  
 DO NOT OVERLOAD

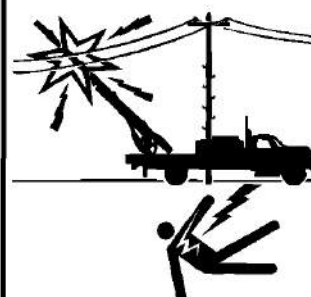
#9

|  |   |  |
|--|---|--|
| <div style="text-align: center;">  <b>DANGER</b> </div> <p><b>Electrocution Hazard</b><br/>         Risk of DEATH or SERIOUS INJURY if conveyor within 20 feet of power lines.</p> <p>It is against Federal &amp; State Law to operate conveyor within 20 feet of power lines.<br/>         ANSI B. 30.5<br/>         29 CFR 1926.1400</p> <p>Hydraulic Fluid must be kept free of water and other contaminants. Because of potential for absorption or infusion of water or other contaminants in the system, frequent sampling is necessary.</p> <p>When replacing hydraulic fluids, the system must be flushed and thoroughly purged of all existing fluids.</p> <p>All surfaces of fiberglass materials must be maintained in a clean and dry condition.</p> <p>High pressure cleaning systems or other high force medium may damage fiberglass surfaces. Once damaged, water or other contaminants may enter the core of the fiberglass matrix creating a conductive channel for electrical current to follow.</p> <p>Use free flow water at standard line pressure or other low pressure device for cleaning purposes. Use caution while cleaning.</p> <p>If you are UNCLEAR or do not UNDERSTAND ANY PART of this WARNING - Contact the Manufacturer at 1-800-453-2446 for information.<br/>         DO NOT PAINT OVER THIS OR ANY OTHER LABEL.<br/>         CALL 1-800-453-2446 FOR FREE REPLACEMENT LABELS.</p> |  | <div style="text-align: center;">  <b>PELIGRO</b> </div> <p><b>Peligro de Electrocución</b><br/>         Riesgo de MUERTE o LESIÓN GRAVE si el transportador o la carga entra en contacto con o se aproxima a las cables de alta tensión.</p> <p>Es contra la Ley Federal y Estatal operar un transportador a menos de 6 metros de los cables de alta tensión.<br/>         ANSI B. 30.5<br/>         29 CFR 1926.1400</p> <p>Se debe mantener el Líquido Hidráulico libre del contacto con el agua y otros contaminantes. Debido al potencial de filtración o infusión de agua u otros contaminantes en el sistema, es necesario un muestreo frecuente.</p> <p>Cuando se reemplazan los Líquidos Hidráulicos, se debe purgar el sistema y depurar perfectamente todos los fluidos existentes.</p> <p>Todas las superficies de material de fibra de vidrio deben mantenerse limpias y secas.</p> <p>Los sistemas de limpieza de alta presión u otros medios con altos niveles de fuerza pueden dañar las superficies de fibra de vidrio. Una vez dañadas, el agua y otros contaminantes pueden ingresar al núcleo de la matriz de la fibra de vidrio, creando un canal de conducción para que se transmita la corriente eléctrica.</p> <p>Para realizar la limpieza, utilice agua que no se encuentre saliendo en la línea de presión estándar u otro dispositivo de baja presión. Realice la limpieza con cuidado.</p> <p>Si está CONFUNDIRDO o NO COMPRENDE ALGUNA SECCIÓN de esta ADVERTENCIA - Comuníquese con el Fabricante al 1-800-453-2446 para obtener INFORMACIÓN.<br/>         NO PINTE ESTA O ALGUNA OTRA ETIQUETA.<br/>         PARA OBTENER ETIQUETAS DE REEMPLAZO GRATUITAMENTE, L.</p> |
|--|---|--|

NOTE:  
 NOT ALL WARNINGS ARE MENTIONED IN THESE DECALS. THEY HAVE BEEN SHORTNED TO FIT. DO NOT RELY ON WHAT THESE ILLUSTRATIONS SAY BUT WHAT THE ACTUAL DECALS INFORM.

**CLEASBY CONVEYORS**  
 362 SOUTH MAIN, CLEARFIELD, UT 84015  
 801 773-1311 \* 800 453-2446 \* FAX 801 773-8608

**CONVEYOR, TURNTABLE AND  
TRUCK DECALS  
12-20-05**

#12



**CLEASBY CONVEYORS  
362 SOUTH MAIN, CLEARFIELD, UTAH 84015  
801 773-1311 \* 800 453-2446 \* FAX 801773-8608**



**CONVEYOR, TURNTABLE AND  
TRUCK DECALS  
12-20-05**

#13

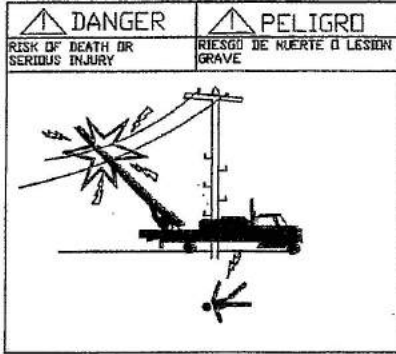

#14

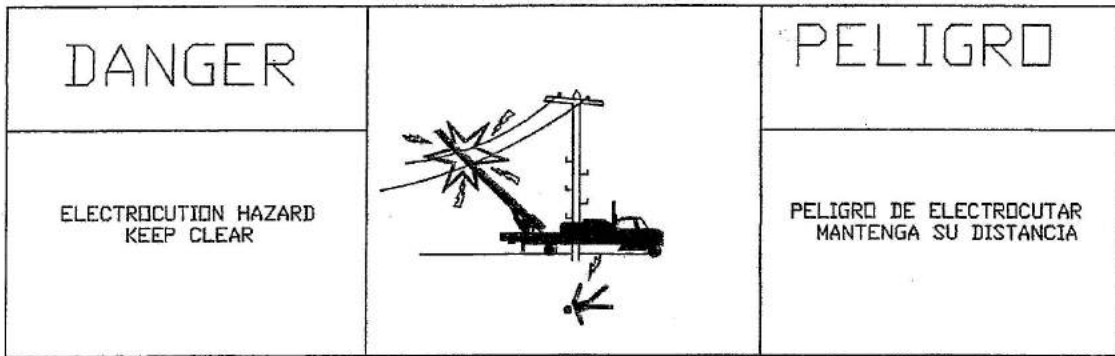

#15

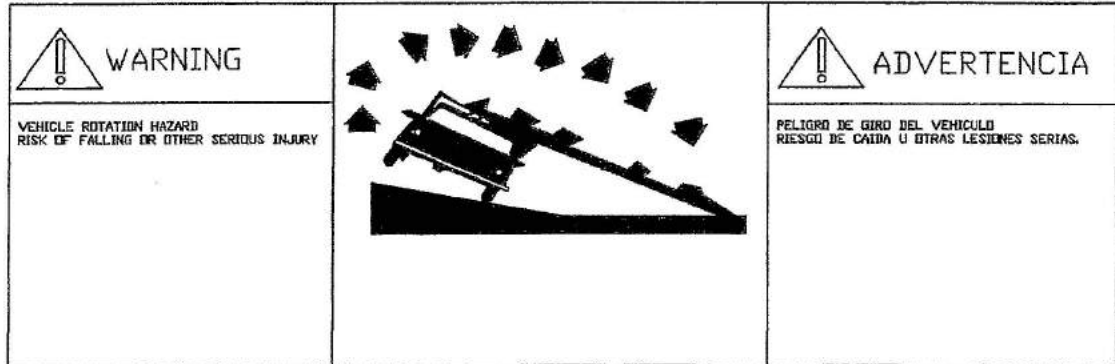

**CLEASBY CONVEYORS  
362 S. MAIN, CLEARFIELD, UT 84015  
801-773-1311 \* 800-453-2446 \* FAX 801-773-8608**

**CONVEYOR, TURNTABLE AND  
TRUCK DECALS**

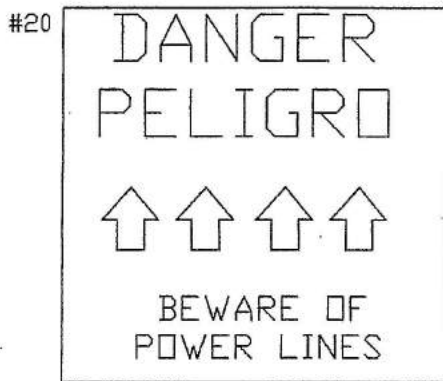
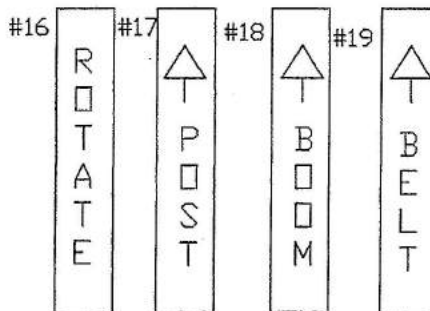

**CLEASBY CONVEYORS**  
362 S. MAIN, CLEARFIELD, UT 84015  
801-773-1311 \* 800-453-2446 \* FAX 801-773-8608